

# Science-based Global Enlightenment in the Quantum-Digital Age (or how to prevent the earth becoming a dead planet)

David Hookes

Department of Computer Science, Liverpool University

Given at the international conference on Big History and Global Futures, Moscow 2015

(download from: <http://pcwww.liv.ac.uk/~dhookes/GEMoscow1.pdf>)

## Prologue:

*“The appearance of the human being marks the beginning of the Age of Intellect, when the leading force of development becomes conscious human creativity and the highest level of organization is the culture of human society. Thus, science is the highest level of the hierarchy in the organization of cosmic matter. It is the highest growth point of a growing tree, the leading shoot in the evolution of the universe. This is the significance of the cosmic phenomenon of science as a part of the phenomenon of man.”*

Valentin Turchin in ‘The Phenomenon of Science’

## Introduction:

This paper starts from the Climate Crisis as part of a global environmental crisis, that is, the poisoning of the water, air, and earth leading to massive loss of biodiversity. With the serious possibility of runaway global warming there is the chance that the earth may become a dead planet.

It further assumes that only if the majority of the world’s people’s demand that this crazy death spiral for life on this planet be halted is there any hope that the vested interests in the present socio-economic system that drive this process can be effectively confronted . The Hyper-Expansionist (HE), growth for-growth’s -sake process must be replaced by a Sane, Humane, Ecological (SHE) economic system[James Robertson (1990)]. But if the present elites refuse to cooperate then an alternative ecological, economic SHE system must be constructed and the HE system allowed to die.

But how do the majority become aware of the urgency of the environmental crisis? The vested corporate and banking interests have control of the mass media and, in large part, the education system - they can thus, at present, manufacture consent for continuing the HE status quo. People become trapped in a work-consumption cycle persuaded that they must ever increase their consumption to be truly happy so they must constantly work

harder to obtain the means to do so. In fact, this process leads to the opposite: unbelievable stress, anxiety, and unhappiness. It will require a major increase in the scientific understanding by the majority of humankind of our relationship with the rest of nature in order to break from the HE economic system and create a SHE future, that is, a new enlightenment.

### **The meaning of the title:**

1. 'Science-based' means that, with its 'critical thinking and testing' method, it is important to distinguish a science-based enlightenment from religious or other mystical forms of so-called 'enlightenment'. After Popper, only concepts and theories that can be tested and can in principle be shown to be false, can be considered 'scientific'.
2. 'Global', means that most of the world's people can become enlightened, in principle, in contrast to the earlier 18<sup>th</sup> century enlightenment in Europe which was largely confined to a narrow, privileged social layer.
3. 'Enlightenment' means something very similar to that of the 18th century in that it says that problems of the world can be understood and solved by scientific reasoning and gathering empirical evidence about the world, as opposed to, for instance, trusting in the received 'wisdom' of holy books or holy women or men.
4. 'Quantum' is for several reasons: Firstly, quantum physics provides an alternative paradigm (see figure 2 below), that is, a local/non-local dialectical paradigm in contrast to the Descartes-Newton local, positivist, mechanistic paradigm [see figure 1 below]. It is also the physics which lies behind new binary Digital Systems (bDS) technology, that is, the technology that can implement the Global Enlightenment. Finally, it is also the physics behind solar energy technologies that will be increasingly needed to power the bDS technology and the new sustainable alternative production processes.
5. 'Digital' is also for several reasons:
  - *The Quantum binary digital system (Q-bDS) of the Universe.* According to leading physicists, the universe itself can be viewed as the holographic projection of binary digital information stored in the quantum fields at the boundary of the universe. [T'Hooft (1993), Leonard Susskind (1995)]. These fields exist (binary digit =1) or not (binary digit=0) in an area of the size of the (Planck dimension)<sup>2</sup> [=Gh/c<sup>3</sup>], that is, about 10<sup>-70</sup> m<sup>2</sup>, or 10<sup>70</sup> bits per m<sup>2</sup>. The universe can thus be viewed as a Quantum binary Digital System (Q-bDS) information processor.
  - *The molecular quaternary digital system for life (qDS):* The evolution of the universe eventually produced a molecular digital system based on a 4-letter code, that is, a quaternary Digital System (qDS), for reproduction and operation of living systems, that is, the molecular genetic code of the DNA-

RNA- Protein System. This 4-letter code, with twenty structural units (amino acids) and a word length of 3 letters (base triplets), that is, a (20,4, 3) code, can be shown to be the optimum code that would be selected by evolution [Davies, Gareth (1995)]. The reason is that it is the one that gives the greatest rate of change of structure, and can, thus, most rapidly adapt to changes in the environment. It will thus outperform other codes. Living systems carry out many millions of digital-to-analogue conversions within each living cell. Each cell actually contains many tens of thousands of digital-to-analogue converters (DACs) called 'ribosomes'.

- *Binary Digital Systems (bDS)*: The qDS molecular technology of nature allowed life to evolve further until it produced its own information processor of sufficient power and complexity, the human brain, which was essential for further cultural and socio-economic evolution of Homo sapiens. This evolution led to the invention of an 'artificial' binary Digital System (bDS) technology, that is, modern information processing technology. The first computers were based on vacuum tubes but they evolved rapidly to be based on the micro- and, now, nano-engineered solid state devices, with billions of transistors per device, each a few 100s of mm<sup>2</sup> in area. It is important to note that the transistors in these devices depend, for their operation, on the same quantum physics that emerged at the creation of the universe.

One of the first tasks of the Quantum-Digital Age [see figure 2] is to use the technologies of bDS and qDS to help solve the crisis of the socio-economic system and the environmental crisis that it has produced, and which threatens to create a dead planet.

### **Drivers for science-based Global Enlightenment:**

1. *Climate crisis*: There is a real possibility of becoming a dead planet and thus it will also mean the end of our planet's Big History and, alas, its Big Historians [Trade Union Climate Summit (2015), Rees, M (2003), Lovelock, J (2006)]. To solve the climate crisis will require an increased awareness of the science of climate change amongst broad layers of the world population through a science-based Global Enlightenment. It will also help to combat the political propaganda of the climate change deniers funded, as they are, by the fossil fuel corporations, and help people to realise that 80% of fossil fuels must be left in the ground to keep the temperature increase below 2<sup>o</sup> Centigrade.
2. *The broader environmental crisis*: This means the pollution of the air, sea, and land, and loss of biodiversity. The latter requires to move from large-scale agribusiness which destroys biodiversity and contributes to poisoning, to agro-ecological farming methods already implemented by the small-scale farmers of the developing world. This process will be greatly enhanced by raising the level of scientific understanding by these communities and creating solar-based technologies to increase the productivity of their labour.

3. *The present unstable socio-economic system of Capital:* The disastrous instability of the present growth-for-growth's-sake socio-economic system of Capital is closely connected to the environmental crisis as shown with great clarity by Naomi Klein in her recent book, 'This Changes Everything'. [Klein, N. (2015)] In this system all the environmental costs of production are said to be 'externalised', that is, ignored. There can be no solution to the crisis unless the system is radically modified or probably replaced by a new system that enables an equilibrium to be established with the rest of nature. One name for the new socio-economic system could be 'The Cooperative Pluralist Commonwealth' [Alperovitz, G (2011) ] which will combine, socially, the innovative talents of all of humanity demonstrated even under the rule of Capital. But this creativity will be released from the restraints placed on it by the social relations of Capital such as class divisions, hierarchies, division of labour, unequal distribution of wealth created by labour, lack of true democracy, etc. (see figure 1) It can be based on entirely new social principles of equality, mutuality, cooperation, and sharing. The active participation of everyone in the productive processes will require an increased awareness of the scientific principles behind these processes as well as a scientific understanding how our production systems impact on the rest of the living world. This can be greatly enhanced by use of bDS both to create a self-organising system using the local/nonlocal quantum paradigm (see figure 2) and to monitor the effects on the environment, including other species, of the production system.

### **The 18<sup>th</sup> Century Enlightenment based on printing, the ICT of the age of Capital.**

As already mentioned we need new Enlightenment of the vast majority of people of the planet- which can be called a science-based Global Enlightenment (GE). The 18C Enlightenment was largely for a narrow social layer of the educated, literate elite although a small fraction of the emerging industrial proletariat was literate and interested in enlightenment ideas. For instance, in England state police spies reported, at the end of 18C, that "every metal-worker in Sheffield had a copy of Thomas Paine's 'Rights of Man' on the shelf above his work-bench". This Enlightenment was made possible by the invention of printing with moveable type, the ICT of its day, by Gutenberg, several centuries earlier. You can consult the two-volume work by US historian Elizabeth Eisenstein, called 'The Printing Press as an Agent of change' [Eisenstein, E. (1979)] and Marshall McLuhan's 'Gutenberg Galaxy' [McLuhan, M (1962) ] for comprehensive accounts of the impact of printing on society.

The most important consequence of this printing ICT was the spread of scientific knowledge for the improvement of human welfare as advocated by Francis Bacon in *Novum Organum* [Bacon, F(1620)] a century or more earlier. Scientific knowledge was also necessary in order to develop an understanding of the natural processes that were being harnessed by emerging industrial capitalism. The ideas of the 18C Enlightenment also led to the creation of bureaucratic structures of the emerging nation states, that is, 'applied reason' [Weber

(1991)] with their top-down, rooted tree-like hierarchies again (figure1). Similar hierarchical structures were created in bureaucratic centralist socio-economy of the former Soviet Union, mistakenly sometimes referred to as 'socialism' or, more jokingly, as 'actually existing socialism'.

### **The stages of capitalist development from mercantile to industrial capitalism**

The first stage of capital system, the mercantilism based on slave labour on plantations, the key technologies were in the field of communication, that is, printing and navigation, and new monetary information systems. Navigation, especially, required the Newton's mechanics and his theory of gravity to understand the motion of planets. Newton was also in charge of the Royal Mint for producing coinage. [see the penetrating study: "The social and economic roots of Newton's Principia"- by Boris Hessen (1930)]. The industrial phase was dominated by control technology, that is, the controlled release of energy from nature so as to, in the first instance, increase the productivity of labour. That meant the use of water power and then steam power. The new steam power also helped to increase the speed of circulation of goods, for example, using railways and steam ships. The science of electromagnetic energy systems was developed in the 19 century after the advent of steam. Even to this day most electrical energy, except for renewable solar energies, is generated using steam (or gas) turbines. Electromagnetism had implications for both the energy systems for production and transport as well as communication (telegraph, telephone radio and television). It was also important for understanding the forces that held matter together and thus led to possibility of transforming matter into more useful forms, that is, the science of industrial chemistry.

### **The social structures of the age of industrial capitalism**

The creation of hierarchical social structures of class societies to maximise the division of labour- was based on the Cartesian- Newtonian world view or paradigm. Human beings in society can be treated as isolated 'particles' controlled within hierarchical bureaucratic structures necessary for capitalist state to control the overall social and economic system[See Figure 1 below]. It is also necessary to release the spirit of capitalism within individual entrepreneurs, and increase the efficiency of the economic system of capital. [Weber(1991)]. It also assumed that human consciousness was completely separate from the material world rather than arising from our social being in that world.

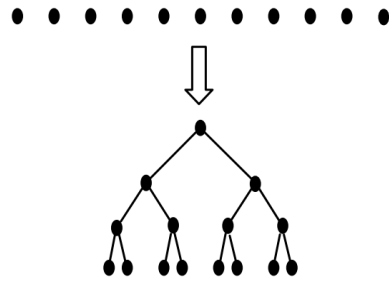

### The Cartesian-Newtonian Paradigm

- \*Nodes are only localised
- \*Hierarchical \*Bureaucratic
- \* Alienating \* Undemocratic

**Figure 1 The paradigm for the 18C Enlightenment and the capital system**

Hidden within the inventions and systems of industrial capitalism were the seeds of its opposite. It is not widely known that Marx saw the revolutionary significance of the creation of machines and especially the new means of communication in his concept of the General Intellect which is to be found in the ‘Fragment on Machines’ in the Grundrisse:

*“Nature builds no machines, no locomotives, railways, electric telegraphs, self-acting mules etc. These are products of human industry: natural material transformed into organs of the human will over nature, or of human participation in nature. They are organs of the human brain, created by the human hand: the power of knowledge, objectified. The development of fixed capital indicates to what degree general social knowledge has become a direct force of production, and to what degree, hence, the conditions of the process of social life itself have come under the control of the **General Intellect** and have been transformed in accordance with it.”*

From Grundrisse [Marx, K (1973)]

Thus bDS technology, created by the capitalist economic system, can be thought of as the technology that can fully implement the General Intellect anticipated by Marx. One can consult Paul Mason’s new book, *Post-Capitalism: a guide to our Future*”, for further discussion of the General Intellect, which also discusses the importance of the Kondratiev cycle theory of economic development of capitalism [Mason, P (2015)]. This bDS technology is a synthesis of the technologies associated separate phases of the development of capitalism, that is, human and non-human communications and the control of the productive processes. Thus, bDS has had, and is having, revolutionary consequences both within the sphere of economic as well as cultural production. Whereas it took several centuries for printing ICT to make possible the 18C Enlightenment, the bDS technology of modern ICT is so powerful that it can, in principle, create a Global Enlightenment in decades rather than centuries. It is thus possible to implement a ‘Quantum’ paradigm using digital technology. This is illustrated by figure 2 below showing a nested-cyclic graph digital information network, which has been borrowed from a representation of the connection between categories within Hegel’s dialectical logic [Sinowiecki, A. (1973)]. In such a graph

the information flows through every node. Such networks, implemented with digital systems technology, can dynamically reconfigure itself. These graphs can be used to model a new system of production system, a problem-solving intelligent network (PSI-net or  $\Psi$ -net), or a network for collective social action.

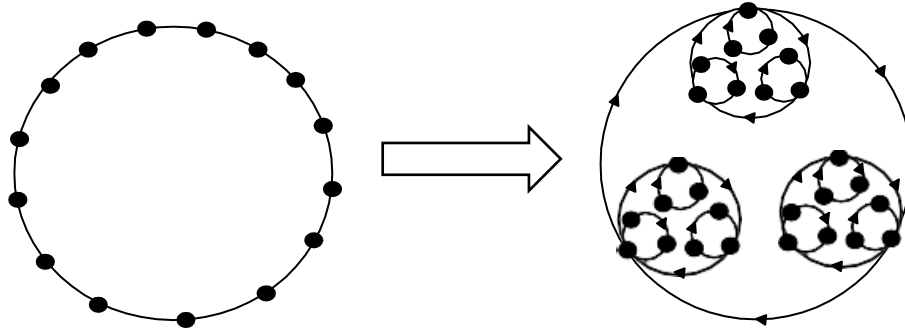

**Properties of the new paradigm:**

- \* Non-hierarchical
- \* Democratic
- \* Non-alienated
- \* Quantum
- \* Fractal

**Figure 2 The Quantum-Digital paradigm  
For a Global Enlightenment**

**Binary Digital Systems and the major developments of modern science**

The binary Digital Systems, created by modern science, were also intimately involved in recent revolutionary developments within science itself, of which we need only consider the most important: 1. The decipherment of the molecular genetic code for life (qDS) and its significance for understanding of evolution, the cause and cure of many diseases, and how to repair the environment and avoid further damage; 2. The understanding of the evolution of the universe, from the Big Bang to the present; 3. The structure of matter down to the present 'fundamental' entities such as: quarks, gluons, leptons, W,Z bosons and recently, the Higgs boson.

1. It is important to understand the role of bDS in the discovery of qDS. In fact, the creation of the science of molecular biology has at every stage depended upon the availability of digital computers firstly to calculate or predict diffraction patterns from protein and DNA crystals, then to handle and analyse the data from the various genome studies culminating in the human genome project. The various spin offs such as genomic medicine will continue to require the close relationship between the two. Many other branches of medicine also require bDS technologies such as X-ray and Magnetic resonance imaging. The medical systems of the future can be thought of as part of a synthesis of qDS and bDS.

2. Modern astronomy at all wavebands is now inconceivable without bDS. Most if not all large telescopes and telescope arrays use digital imaging cameras and also are operated remotely by computers which also analyse the data. So the present rapid development of our understanding of the history of the universe is closely linked to the emergence of bDS. Thus Big History as a subject is itself dependent on bDS.
3. The operation of, and analysis of the results from the Large Hadron Collider at CERN is inconceivable without bDS. LHC generates about 6 petabytes ( $10^{15}$ ) of data every second which is logged and analysed by a global grid of computers.. The discovery of the Higgs boson is latest triumph of the LHC, which completes the standard model of elementary particles. CERN itself was also the location for the invention of the World Wide Web.

## Solar Energy and Global Enlightenment

As has been pointed out by my 'Scientists for Global Responsibility' (SGR) colleague Keith Barnham in his important recent book on the solar energy revolution, "The Burning Answer", says we have to choose between two equations for our energy future [Barnham, K (2014)]. The first one is the Planck-Einstein equation,  $E=hf$ , used by Einstein to explain the photoelectric effect, and the second, Einstein's most famous equation,  $E=mc^2$ , that determines the energy released in nuclear processes. He assumes that most fossil fuels will have to be left in the ground if we are to survive as a species and says that nuclear power is too expensive and dangerous with a radioactive life cycle of 100,000s of years. So we are left mostly with the various forms solar energy, especially Photo-Voltaic (PV), as necessary to power the Global Enlightenment. Fortunately, it is an immediately available technology to the 1.5 billion people who are "off-grid", and thus do not have access to electricity and thus would therefore not be able readily to become part of Global Enlightenment. The cost of installing solar PV has dropped by a factor of ten in recent years due to the mass production of solar cells in China –it is now about the same cost to install a kW as for a kW of fossil fuel power. There also new types of solar PV cells such as those developed by Keith Barnham's group at Imperial College, London, in association with several other groups. These cells are 42.5% efficient that is three time more efficient than the conventional silicon diode technology. These devices use 'quantum well' technology that is also present in the antenna of mobile phones.

Solar PV is a very flexible energy source and can be converted in liquid or gaseous forms such as hydrogen. It has been shown to be a technology that can regenerate depressed urban and rural areas, for instance, in inner-city Cleveland, Native American communities, and communities in Africa, India and elsewhere.

Most villages in developing countries could be rapidly electrified with this technology in a short space of time if sufficient resources are made available, for instance, those diverted from arms production. This solar energy could be used to create lighting, water pumping from depth and for irrigation; education facilities linked to the internet, medical facilities such as cool-rooms for storing medicines. One example of how this can be carried out is by using solar-powered shipping containers that have been developed in Germany [figure 3



below]. Even without a coordinated global plan there is rapid growth in solar PV installation of 20-30% per annum, albeit from a low base.



**Figure 3 A solar-powered shipping container**

To summarise:

**Solar Energy+ Binary Digital Systems = Global Enlightenment = a stable planet**

### **Science as a Universal Discourse**

Science provides both the technology for creating Global Enlightenment but also its method of critical thinking that can help solve the environmental and socio-economic problems confronting our species.

Digitally-driven mass media has penetrated all aspects of social and cultural life. However, under present dominant socio-economic system this is often used to enable the commodification of all human activities and increase alienation, anxiety, fear and depression. There is, thus, an abuse of this revolutionary technology by the elites, to mislead and misinform the population as well as to manufacture political consent. [Chomsky, Herman (1994)]. The present use of digital mass media through advertising to encourage excessive consumption rather than living within our means is also an abuse of the power of technology. As Benjamin Barber has argued convincingly this consumerism leads to a form of 'infantilism' amongst adults, the corruption of childhood, and the decline of democratic participation [Barber (2007)]. But it is possible to show, using scientific reasoning, that this excess consumption is completely unsustainable. For instance, one

would need four or five planets if everyone on earth consumed as much per capita as people in the USA.

But the revolutionary product of scientific activity, bDS, can also provide the means of to counteract its own abuse. Science and its method is the only basis for a Universal or Global Discourse. Religious thinking has signally failed to create such a discourse, producing the very opposite, Universal Confusion and Conflict. Art does have universal aspects such as symmetry and beauty and thus can enhance the Global Enlightenment process, but is also influenced by local cultural biases. However, the bDS technology allows dynamical networks of social, economic, and cultural actors to be realised on a global basis reflecting the universal discourse of the science that created it.

## **How to create a Global Enlightenment?**

It is easy to judge that there is a need for a Global Enlightenment but not so easy to map out a plan to bootstrap such a development.

One must surely start with present education system. But this system, at present, is largely in the hands of national and local state bureaucracies, which will be susceptible to pressure from vested interests in the present socio-economic system.

1. ***The world university system:*** This system already demonstrates a global network of knowledge sharing and collective knowledge creation. Many academics publish papers with colleagues from different countries so that, in many ways, the Higher Education system is a precursor of a Global Enlightenment.
2. ***The secondary education system:*** The university sectors in every country can also enable the secondary sector to develop global linkages, using the Higher Education network as a template for a schools network. Each University could have its own special department to promote its own Higher Education global links and its links with its local secondary schools. With the university support secondary schools can be helped to develop links with schools in other parts of the world. One approach would be to include a module in every school syllabus that treats the environment as a global problem, especially the issue of climate change. So that every child from an early age begins to see themselves as global eco-citizens. Using the internet and the school twinning they can carry out joint science -environmental projects involving several schools on different continents. This will need, in some cases, the creation of special digital instrumentation to take measurements and provide it in suitable form for computer analysis and internet transmission.

3. **Primary school System:** Secondary schools can link with primary schools and help them form links with other primary schools across the world so even at very early age children will be encouraged to think of themselves as participating in global friendships and be part of a global community.

In both Secondary and Primary schools each school can have cross-curricular core theme about our common environment and its problems. This theme will especially encourage students to see themselves as part of a same species rather than just members of a special national, ethnic, or cultural sub-groups. It can also help introduce the idea of the inter-connectedness of all human knowledge, and thus an underlying principle of Big History. They can be introduced early on to the idea that science is a universal language or discourse which will also help them to see themselves a part of a single species. There will, of course, be opposition to this approach due to the role of education, traditionally, to inculcate acceptance of the status quo, loyalty to local, national, and ethnic identities.

4. **Special bDS educational technology:** It is possible to create computer-linked **digital** instrumentation for teaching science that can overcome the problems of understanding that are largely of a social-cultural nature. An example would be my Physics-is-Fun Workstation (PFW) [see figure 4 below ]. Physics is the basis of the natural sciences but also often one that presents difficulties for many children, creating a barrier for progress to higher education in other applied sciences from medicine to engineering. So creating a computer-interactive workstation for learning physics in a fun way, and that can be mass-produced, may be a step in the creation of a global learning network as part of the development of Global Enlightenment. The PFW is designed so that students can create their own projects and test their understanding. They can also collaborate with students in other countries, sharing data and comparing results [Hookes, D. (1997)]

## The Physics Workstation

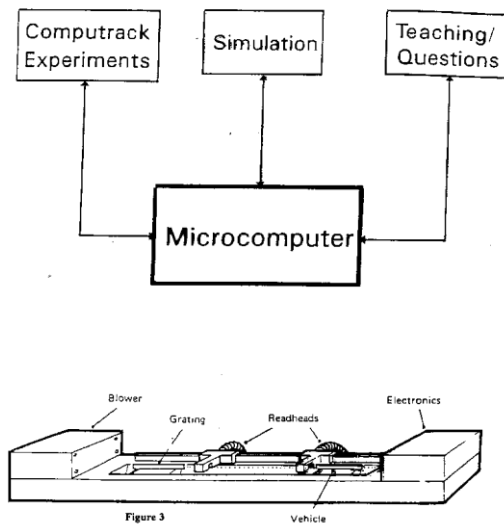
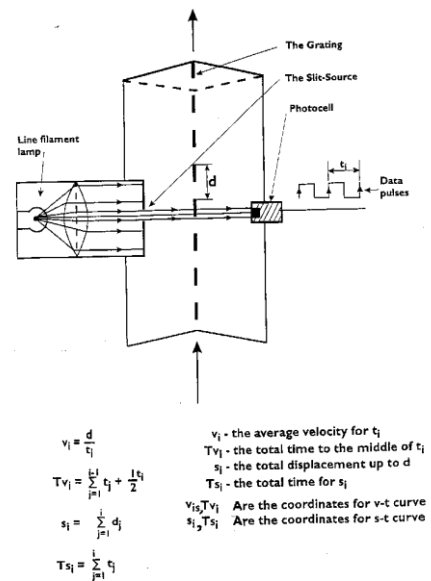

Figure 4 The Physics- is-Fun Machine (PFM)

The principle of the Slit-source, Grating and Photocell method (SGP)



## How to fund the solar energy for science-based Global Enlightenment?

There are several possibilities:

1. *Use the funds created under Copenhagen Climate Change Accord:* These funds were promised under the Copenhagen Accord for developing countries to mitigate or adapt to the effects of climate change – they are supposed to reach \$100Bn per annum by 2020. Installing solar technology in every village is a major step in helping countries to develop in a sustainable manner. It would also help in making scientific understanding accessible to all.
2. *Create a Global Enlightenment Trust – GET.* The software and hardware created for implementing Global Enlightenment can be assigned to **GET** under a 'creative commons' license. It can be considered Open-Source or Open-Tech as illustrated by the creation of the LINUX operating system. The funds can also generated from IPR lodged with GET by inventors who support its aims, namely, to save the planet from a heat death. For instance, the IPR for the PFW would be held by this trust. Another example is the Japanese scientist/engineer who invented the blue LED, a major breakthrough in creating white-light LEDs, which are many more times efficient than filament bulbs, donated some of the money he eventually obtained from his invention to help found Engineers-without-Borders.
3. *Individual donations:* If the GET is successful in promoting Global Enlightenment, that is, it takes off, it is not difficult to imagine that it would eventually attract, say, 10 million supporters amongst the so-called 'Golden Billion' of the world's population,

that is, 1% of those with disposable income. An important section would be the knowledge workers, 40 % of workers in advanced economies, who can most readily appreciate the dangers of global warming. They would, thus, understand the need to avoid the tipping point for runaway warming, which could lead to a dead planet. If each of the 10 million gave a donation of \$10 per month then there would be a monthly income of \$100m or \$1.2Bn annually. This would be sufficient to electrify, 20,000 villages a year through solar PV to provide pumping for clean water, lighting for night time study, medical cool rooms, and access to the internet for science education using the solar-powered shipping containers mentioned above.

## **Conclusion:**

In order to create a science-based Global Enlightenment we will require a major cooperative action on a global scale, especially among scientists and engineers. This not at all an impossible vision, giving the nature of the threat to life's continued existence on this planet.

As Jeremy Rifkin has pointed out in "The Empathic Civilisation" [Rifkin, J (2009)] human beings have an intrinsic feeling of empathy for others. Such a view is opposed by those who represent the views of the 1% who benefit from the HE economic system. As they would have it humanity is composed of aggressive, greedy, competitive individuals who have no concern for others other than themselves and their immediate family. This view is very rarely challenged in the main stream media (MSM) and often revealed in comments about the intrinsic wickedness of 'human nature' promoted by some religions. But if it were the case then war would be popular which it is most certainly not. Most people prefer to cooperate with each other and help each other. The greedy aggressive competitive individual is distinctly unpopular in the workplace or any other social context.

## **Cooperation as a key principle in the evolution of the universe:**

It can be shown that 'cooperation' rather than competition is a leading or a key principle in the universe, from its earliest beginnings when two UP quarks cooperated with a DOWN quark to form a stable proton to the cooperative processes that led to evolution, and later the development of language for social cooperation that enabled our species to emerge from the hominin genus [Hookes, D. (2014)]. The role of various information technologies can help explain the increasing tendency of our species to form larger and larger cooperating social groups. It can be argued we are, at present, stuck in an evolutionary halfway house between the pursuit of individual goals that is 'individualism' within subgroups of our species which is preventing us from reaching a higher level of species-wide cooperation. This requires, as in similar earlier transitions within biological and social evolution, the emergence of new information technology to enable or stabilise a transition to a higher level of cooperation. That information technology has now arrived in the form of binary digital systems technology, and the transitional form in which it operates can be identified as the Global Enlightenment.

Modern science shows us that we are one species. The spread of science and the scientific method of critical thinking and testing will help us to realise this understanding in practice. It will also show us how to resolve the critical problems of the environment and the socio-economic system of capital that has created these problems.

I wish to finish with advice from one of the greatest scientists of all time and the words of a popular song from my home town of Liverpool. Each captures the essence of what I have been trying to say:

*“A human being is part of the whole called by us the Universe, a part limited in space and time. She experiences herself, her thoughts and feelings, as something separated from the rest, a kind of optical delusion of her consciousness. This delusion is like a prison for us, restricting us to our personal desires, and to affection for a few persons nearest to us. Our task must be to free ourselves from this prison by widening our circle of compassion to embrace all living creatures and the whole of nature and its beauty.”*

Albert Einstein

Perhaps we can also agree with the words of a popular song from my Liverpool school contemporary:

### **Imagine** by John Lennon

Imagine there's no heaven  
It's easy if you try  
No hell below us  
Above us only sky  
Imagine all the people living for today

Imagine there's no countries  
It isn't hard to do  
Nothing to kill or die for  
And no religion too  
Imagine all the people living life in  
peace, you

You may say I'm a dreamer  
But I'm not the only one  
I hope someday you'll join us  
And the world will be as one

Imagine no possessions  
I wonder if you can  
No need for greed or hunger  
A brotherhood of man  
Imagine all the people sharing all  
the world, you

You may say I'm a dreamer  
But I'm not the only one  
I hope someday you'll join us  
And the world will be as one

**Another Globally Enlightened World is Possible!**

## References:

- Alperovitz, Gar (2011) *America after capitalism* Democracy Collaborative Press, Takoma Park, Maryland, USA
- Bacon, Sir Francis (1620) *Novum Organum* from: <http://oll.libertyfund.org/titles/1432>
- Barber, Benjamin (2007) *Consumed: How markets corrupt children, infantilise adults, and swallow citizens whole* W. W. Norton & Co, New York
- Barnham, K (2014) *The Burning Answer (p.17)* Weidenfeld and Nicholson, London, England
- Chomsky, Noam, Herman, Edward, (1994) *Manufacturing Consent* London: Vintage
- Davies, Gareth (1995) *The evolutionary origin of the genetic code* Personal communication
- Eisenstein, Elizabeth (1979) *The printing Press as an Agent of Change* Cambridge University Press, Cambridge.
- Hessen, Boris *The Socio-Economic Roots of Newton's Principia*, The Second International Congress on the History of Science, London, 1931.
- 't Hooft, Gerard (1993) *Dimensional reduction in Quantum Gravity* <http://arxiv.org/abs/gr-qc/9310026>
- Hookes, David (1997) *Science Education, New Technology, and Development: A Computer-interactive 'Physics-is-fun' Workstation for Distance Learning* Conference on Science and Technology for Development, University of Durban, Pietermaritzburg, South Africa. 1997
- [Download from: <http://pcwww.liv.ac.uk/~dhookes/SciDEV1.pdf>]
- Hookes, David (2014) *Cooperation: a key principle in the evolution of the universe, from quarks to quare fellows*: <http://pcwww.liv.ac.uk/~dhookes/cooperation.pdf>
- Klein, Naomi (2014) *This changes everything*: Allen Lane, Penguin Books, London, UK
- Lovelock, James (2006) *The revenge of Gaia* Allen Lane, Penguin Books, London, UK
- Marx, Karl (1973) *Grundrisse: Introduction to the critique of Political Economy* (p 706) Penguin Books, Harmondsworth, Middlesex, England
- McLuhan, Marshall (1962) *The Gutenberg Galaxy*: Routledge and Kegan Paul Ltd, London
- Rees, Martin (2003) *Our Final Century* William Heinemann, London, UK
- Rifkin, J (2009) *The Empathic Civilisation: The race to global consciousness in a world in crisis* Polity Press (2010) Cambridge, UK
- Robertson, James (1990) *'Future Wealth: New Economics for the 21st Century'* Bootstrap Press, New York

- Synowiecki, A. (1973) *Hegel's Logic in the Light of Graph Theory*  
XV World Congress of Philosophy, Polish Phil. Quarterly, 1973
- Susskind, L (1995). *The World as a Hologram*. Journal of Mathematical Physics **36** (11): 6377–6396.
- Trade Union Climate Summit (2015) *No jobs on a dead planet!* [http://www.ituc-csi.org/IMG/pdf/draftagenda\\_no\\_jobs\\_on\\_a\\_dead\\_planet29jul.pdf](http://www.ituc-csi.org/IMG/pdf/draftagenda_no_jobs_on_a_dead_planet29jul.pdf)
- Turchin, V (1977) *The Phenomenon of Science page 241* University of Columbia Press, New York Download from <http://pespmc1.vub.ac.be/POS/TurPOS.pdf>
- Weber, Max (1991) *From Max Weber: Essays in Sociology* p196 ff. Edited by Gerth, H and Wright-Mills C (second edition), Routledge, London, UK